

Assembly Instructions

XL

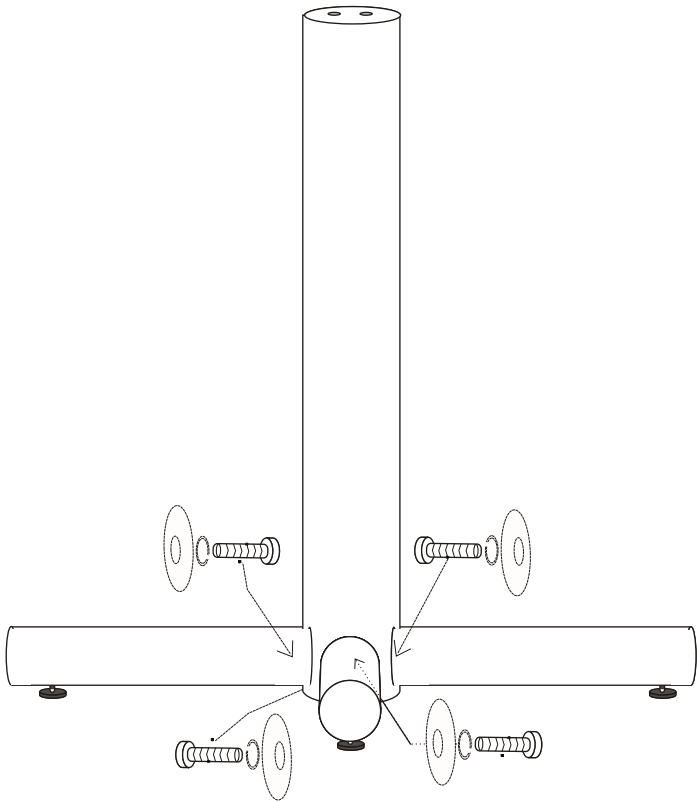

Components needed for assembly:

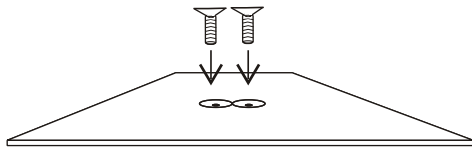
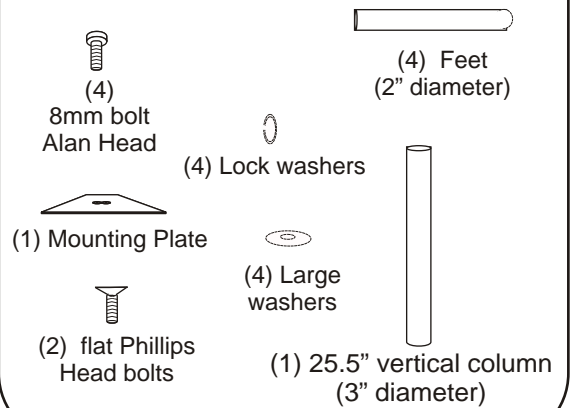

Instructions

1. Holding upright, insert (2) flat Phillips head bolts through the mounting plate and into the top of vertical column.
2. Tighten bolts securely with Phillips ratchet wrench.
3. Invert assembly and attach (4) feet to the column by inserting (4) 8 mm bolts, lock washers and large washers from the center of the column into the feet. Hand tighten the bolts.
4. Using 13mm ratchet wrench, tighten bolts securely.