

SPECIAL

XL Base Assembly Instructions

Parts Included:

- A Welded foot (with glides)
- B Column
- C Mounting plate (with set screw "D")
- D Set Screw
- E Rod
- F Phillips pan head screws
- Optional casters

Tools Needed:

- Phillips screwdriver or impact drill
- 3/8" hex bit
- 18mm socket
- Safety glasses

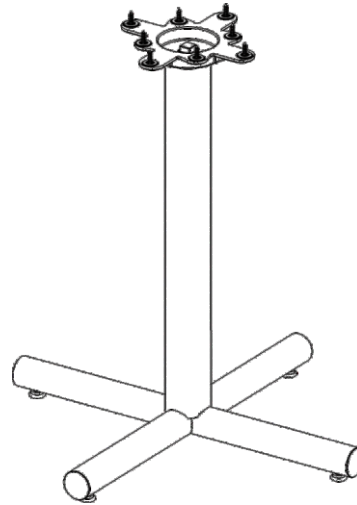

**If you are missing parts
or have any questions
about the product,
please call Customer
Service at 888.705-0777.**

Instructions

Base Assembly:

1. Place column (B) on top of the welded foot (A)
2. Place mounting plate (C) on top of the column (B)
NOTE: set screw (D) must be inserted in the slot on the top of the column.
3. Insert rod (E) through the mounting plate (C) and column (B) and screw into the welded foot. Tighten the rod with 19mm socket.

NOTE: If using optional casters, install them on the welded foot (A).

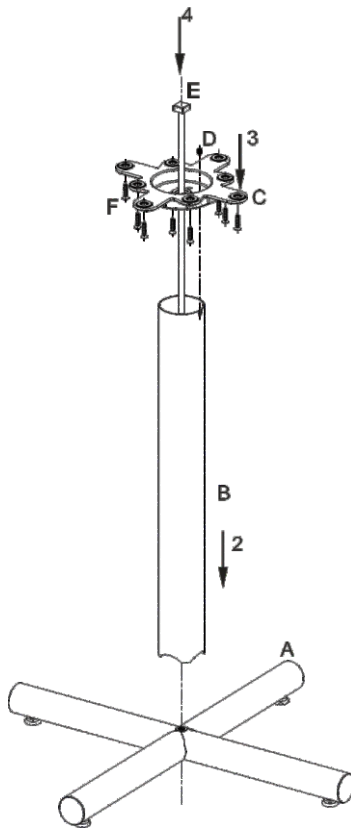

**START BOLTS BY HAND TO
PREVENT CROSS THREADING**

11.2012

